



Digital Temperature Controller

CONOTEC CO., LTD.

www.conotec.co.kr



FOX-2001FD

Operating Manual

Model	Sensor	Output	Temp. range	Function
FOX-2001FD	NTC	Relay (4EA)	-55.0°C ~ +99.9°C	temp. control

※ Thank you for selecting our products. Please read carefully this instruction to reduce any damages or operation mistakes.

Part name

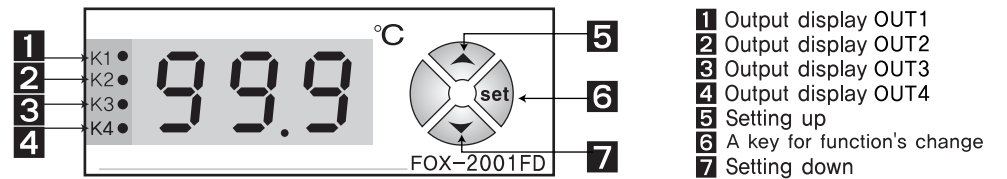

- 1 Output display OUT1
- 2 Output display OUT2
- 3 Output display OUT3
- 4 Output display OUT4
- 5 Setting up
- 6 A key for function's change
- 7 Setting down

The function of each key

- 1. **set** : A key to change of the programs & setting temperature
- 2. **up/down** : A key to change of the program's set values & temperature.

Detailed manual

1. **E81** : To change the set values for the main output.
2. **E82** : To change the set values for the auxiliary output.
3. **HSP** : Setting function of the highest limit of temperature range (Maximum set point allowed to the end user)  
Impossible to set up the set value more than **HSP** set value  
ex) **HSP** = 25°C setting ⇒ impossible to raise the set value more than 25°C
4. **LSP** : Setting function of the lowest limit of temperature range (Minimum set point allowed to the end user)  
Impossible to set up the set value less than **LSP** set value  
ex) **LSP** = 10.0°C setting ⇒ impossible to lower the set value less than 10.0°C
5. **LYP** : Selection of the cooling or heating function
6. **d1 F** : Setting for temperature deviation
  - In the ON/OFF control, it needs at regular interval between ON and OFF.
  - By operating the ON/OFF control frequently, the relay or its output contact can be damaged quickly and it also occurs the hunting(oscillating, chattering) by virtue of external noise. You can make use of the temperature deviation in order to protect its relay or contact and so on.

ex ⇒ The method of the temp. deviation when ON/OFF control

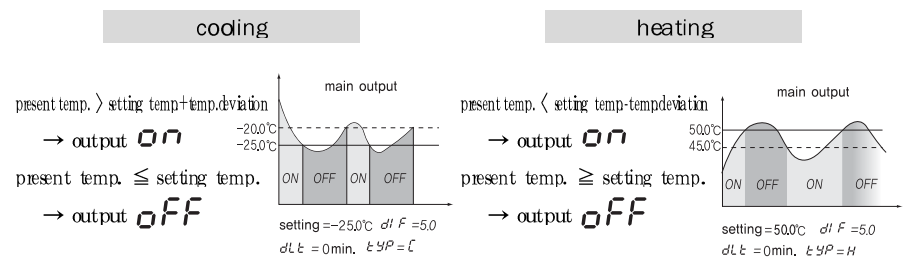

7. **dLt** : Delay time of the output  
It is widely used as the followings
  - in case of operating the ON/OFF control very often,
  - to protect the operation machinery when re-input of the power supply or momentary stoppage of power supply

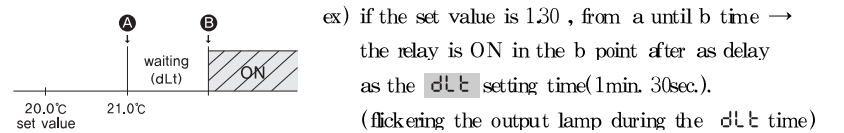

8. **Cor** : Correction of the present temperature.  
- It is used for the correction of a discrepancy between the display temperature and real temperature  
ex) real temp. : 10.0°C → **Cor** : 0.0 ⇒ -2.0 correction → 10.0°C display

9. **LoL** : The lock function  
As a safety device, it is used in order not to change the set values except for the main user.  
ON - setting for the lock function.  
OFF - removal for the lock function.
10. **d1** : auxiliary output → operation by the temp. deviation set value
11. **dF2** : setting for the temp. deviation of the temp.2 - see the no.6
12. **dF3** : setting for the temp. deviation of the temp.3 - see the no.6
13. **dF4** : setting for the temp. deviation of the temp.4 - see the no.6

ex) setting : 15.0°C, **LYP** : C  
**d1 F** : 1.0, **dF2** : 2.0, **dF3** : 3.0, **dF4** : 4.0

ex) setting : 25.0°C, **LYP** : H  
**d1 F** : 1.0, **dF2** : 2.0, **dF3** : 3.0, **dF4** : 4.0

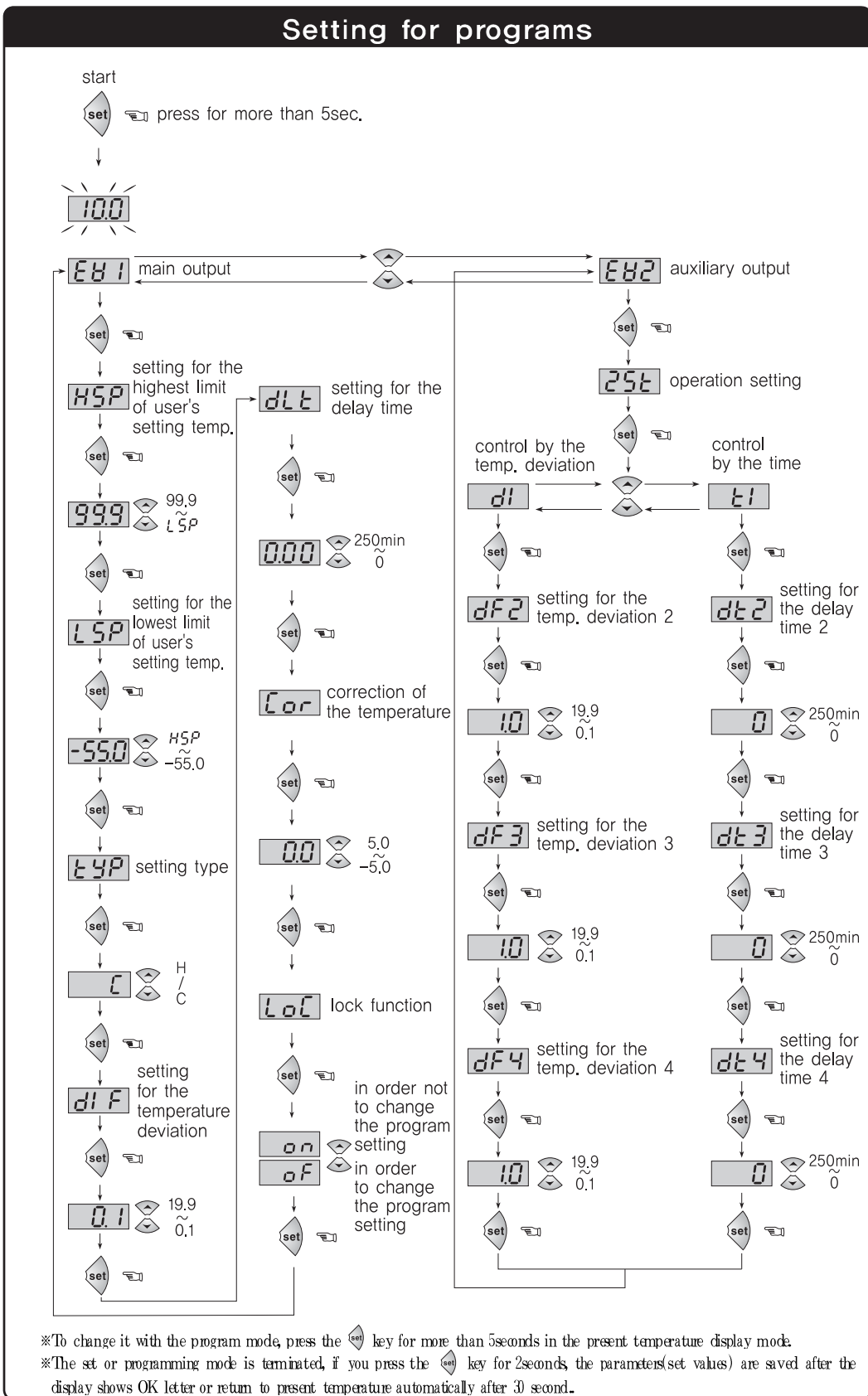
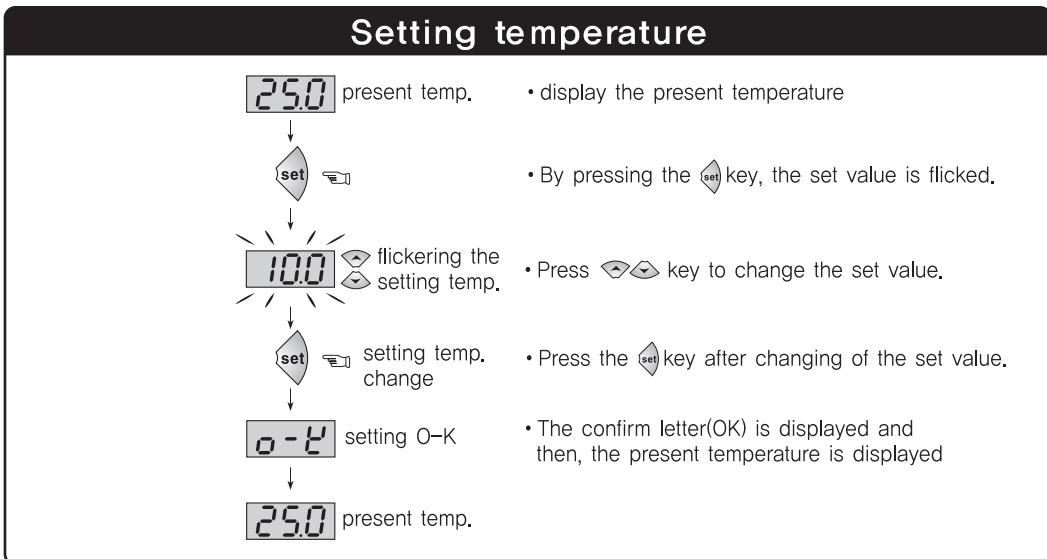
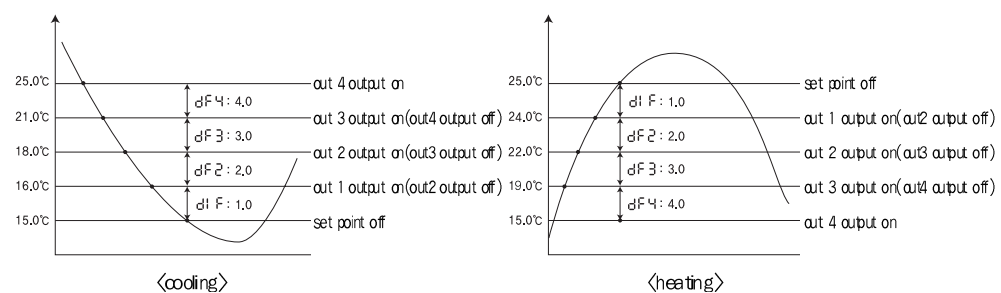

※To change it with the program mode, press the **set** key for more than 5seconds in the present temperature display mode.  
※The set or programming mode is terminated, if you press the **set** key for 2seconds, the parameters(set values) are saved after the display shows OK letter or return to present temperature automatically after 3) second.

- 14.  $\epsilon 1$  : auxiliary output  $\rightarrow$  operation by the delay time set value
- 15.  $d\epsilon 2$  : setting for the delay time of the temp.2 - see the no.7
- 16.  $d\epsilon 3$  : setting for the delay time of the temp.3 - see the no.7
- 17.  $d\epsilon 4$  : setting for the delay time of the temp.4 - see the no.7

ex) setting : 15.0°C  $\epsilon 3P$  : C,  $d\epsilon 1$  : 1min,  $d\epsilon 2$  : 2min,  $d\epsilon 3$  : 3min,  $d\epsilon 4$  : 4min.

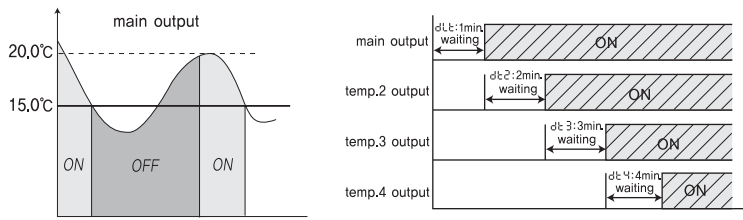

### temp. range & set value when deliver

Function	Display	Range	Set values when deliver	Remarks	
Setting temp.	Setting temp.	-55.0°C~99.9°C	10.0°C		
Program Setting	$\epsilon 81$ : Setting for the highest limit of user	HSP	1.5P~99.9°C	99.9°C	It is irrelevant to the relay output.
	Setting for the lowest limit of user	LSP	-55.0°C~HSP	-55.0°C	It is irrelevant to the relay output.
	Selection of the type	$\epsilon 3P$	$\epsilon$ / H	$\epsilon$	H - heating $\epsilon$ - cooling
	Temperature deviation	dIF	0.1°C~19.9°C	1.0°C	hysteresis +
	Delay time	dL	0~250min	0min	
	Correction of temp.	Cor	-5.0~5.0		correct for a discrepancy between the display temp. and real temp.
	Lock function	LoC	on/off	oF	oN - setting for the lock function oF - removal of the lock function however, except for the setting temperature value.
$\epsilon 82$	auxiliary output	2St	d1 / $\epsilon 1$	d1 $\epsilon 1$ - operation by the delay time	
	temp.2 - temp. deviation	dF2	0.1°C~+19.9°C	1.0°C	setting for the set value of the temp.2 output * the main output ON point basis
	temp.3 - temp. deviation	dF3	0.1°C~+19.9°C	1.0°C	setting for the set value of the temp.3 output * temp.2 output ON point basis
	temp.4 - temp. deviation	dF4	0.1°C~+19.9°C	1.0°C	setting for the set value of the temp.4 output * temp.3 output ON point basis
	Delay time for the output of the temp.2	d $\epsilon 2$	0~250min	0min	It is applied to the delay time after operating the main output.
	Delay time for the output of the temp.3	d $\epsilon 3$	0~250min	0min	It is applied to the delay time after operating the temp. 2 output.
	Delay time for the output of the temp.4	d $\epsilon 4$	0~250min	0min	It is applied to the delay time after operating the temp. 3 output.

### Relay junction

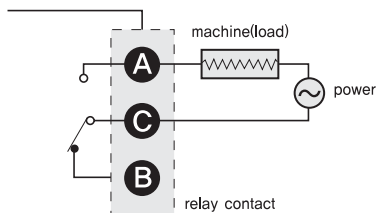

### Connection

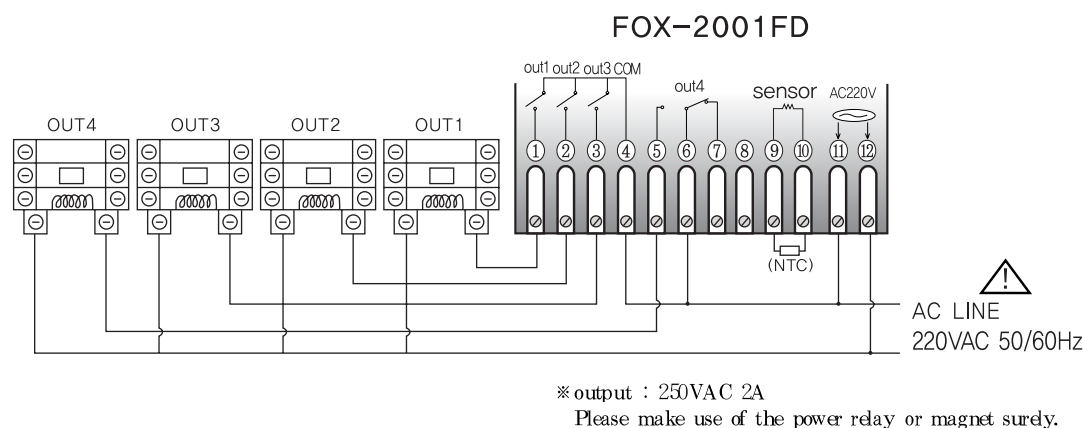

### Size & dimension

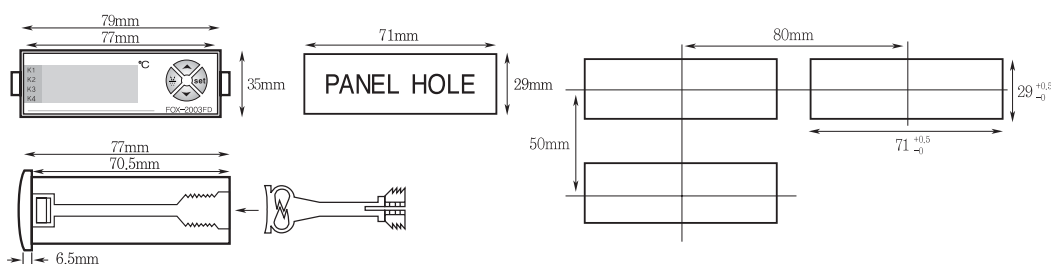

### Safety and Hazard Instructions



Pls use this item after installing the duplex safety device in which is applied at dangerous factors such as serious human injury or serious damages of property & important machine because this item is not designed as safety device

### Safety Instruction and Hazard Warnings

- Please read the operating manual through completely before putting the device into operation.
- We will not assume any responsibility for damage to assets or persons caused by improper handling or failure to observe the safety instructions or hazard warnings.
- For safety and licensing reasons, unauthorized conversion and/or modification of the device is not permitted.
- Do not exceed the maximum permissible current - in case of higher loads, use a contactor of adequate power. Make sure that the supplied voltage matches the values specified for the instrument.
- The device must be adequately protected from water and dust as per the application and must be accessible via the use of appropriate tools
- The device must not be exposed to extreme temperature, sunlight, strong vibrations or high levels of humidity.
- Operation or installation is not permitted under unfavorable ambient conditions such as wetness or excessive induction loads or solenoid and dust, combustible gases, vapors or solvents, especially high-frequency noise
- Avoid operation or installation close to high-frequency fields such as welding devices, sewing machines, wireless transmitter, radio systems, SCR controller, etc
- Do not install the sensor cable nearby signal cable, power cable, load cable
- Please use the shield cable when the sensor cable's lengthen, however do not make it too much longer
- Please use the sensor cable without any cutting or flaw, blemish.
- The device is not a toy and should be kept away from children
- Installation work must only be carried out by suitably qualified personnel who are familiar with the hazards involved and with the relevant regulations.
- You shouldn't tinker with anything or the product may not be opened or disassembled unless you know what you're doing. Please ask us about this questioning



Attention ! Never work on electrical connections when the machine is switched on

### Error message

- $\epsilon r 1$  Memory error. Turn the power off and turn it on again  
If the error message persists, please request us A/S by return
- $\sigma - E$  Sensor error. The sensor is interrupted. Check the cable.
- $S - E$  Sensor error. The sensor is short-circuited. Check the cable

■ The terms of guarantee : within 18months after shipment date.

### Model & output spec

	2001 (sensor : 1EA)	2001D (sensor : 1EA)	2001T (sensor : 1EA)	2001F (sensor : 1EA)	2000TT (sensor : 1EA)
temp. output	one-stage output	two-stage output	three-stage output	four-stage output	control by the temperature & time (for greenhouses)

	2001 (sensor : 1EA)	2002 (sensor : 1EA)	2003, 2003S (sensor : 1EA)	2004 (sensor : 2EA)	2005 (sensor : 2EA)	2006 (sensor : 2EA)	
temp. output	○	○	○	○	○	temp. 1	temp. 2
alarm output	-	○	-	-	○	alarm 1	alarm 2
defrost output	-	-	○	○	○	-	-
FAN output	-	-	○	○	○	-	-

### ex) application

- ex) heater  $\rightarrow$  turn off at 30.0°C, turn on at 25.0°C, temp. 2 output at 20.0°C, temp.3 output at 18.0°C, temp.4 output at 15.0°C How to operate(setting for the temperature & programs)?

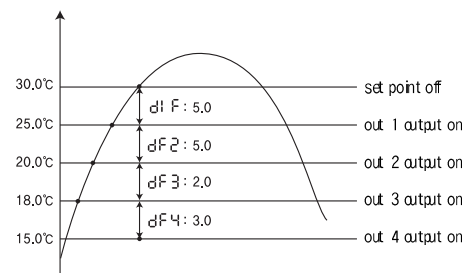

< setting temp. > (see the setting temperature)  
setting : 30.0°C  
< setting programs > (see the setting for program)  
main setting  
 $\epsilon 3P$  : H  
dIF : 5.0 (due to the on/off's interval  $\rightarrow$  5.0°C)  
auxiliary setting  
2St : d1  
dF2 : 5.0  
dF3 : 2.0  
dF4 : 3.0

- ex) cooler  $\rightarrow$  turn off at 0.0°C, restart at 2.0°C, auxiliary output  $\rightarrow$  1minute interval How to operate(setting for the temperature & programs)?

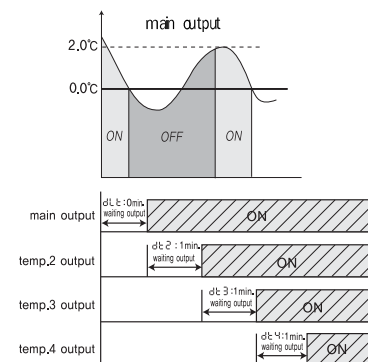

< setting temp. > (see the setting temperature)  
setting : 0.0°C  
< setting programs > (see the setting for program)  
main output  
 $\epsilon 3P$  :  $\epsilon$   
dIF : 2.0 (due to the on/off interval  $\rightarrow$  2.0°C)  
dL : 0minute (set value when deliver)  
auxiliary setting  
2St :  $\epsilon 1$   
d $\epsilon 2$  : 1minute  
d $\epsilon 3$  : 1minute  
d $\epsilon 4$  : 1minute

\*The product's specification can be changed without any notification to improve its quality.

● H.Office : CONOTEC B/D 2nd floor, 26, Yunsan-ro, Geumjeong-gu, Busan, 609-821 Rep. of KOREA  
Lab : CONOTEC B/D 3rd floor, 26, Yunsan-ro, Geumjeong-gu, Busan, 609-821 Rep. of KOREA  
Factory : CONOTEC B/D B1, 26, Yunsan-ro, Geumjeong-gu, Busan, 609-821 Rep. of KOREA  
● A/S TEL : 051 - 819 - 0425 ~ 7  
e-mail : conotec@conotec.co.kr  
URL : www.conotec.co.kr

This device works proper operation with  
surrounding Temp. : 0°C ~ 60°C  
surrounding Humi. : below 80%Rh  
Regular : 220Vac  $\pm$ 10% 50/60Hz

Main products & Development  
- Digital temperature/humidity controller  
- Digital timer, Current/voltage meter  
- The other development products